

Drying

HFDS 2500/600 belt dewatering system

Optimized for dewatering whole and cut fruit and vegetables: The system is integrated into a processing line after the washing process and combined with another belt dewatering system or a continuous centrifuge.

up to 2,000 kg/h Max. capacity

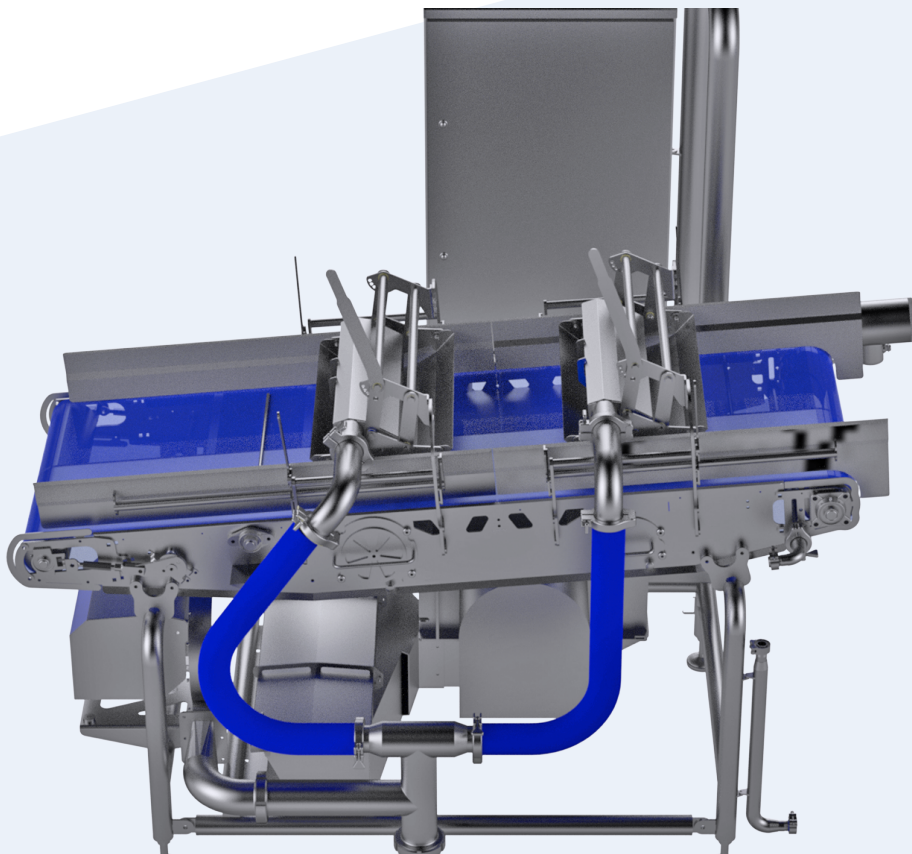

Your benefits

- ✓ Continuous dewatering: designed for large processing lines
- ✓ Gentle drying of whole and cut products
- ✓ Combination of swirling and suction removes surface water particularly effectively

Portrait

Ideal for fruit and vegetables: dewatering up to 2,000 kilograms of whole or cut products per hour

The HFDS 2500/600 from KRONEN's partner company Hitec Food Systems is a dewatering system accommodated in a line after the washing process and prior to packaging. The system is particularly suitable for whole products such as potatoes, snack cucumbers, apples or sultanas, as well as for sliced products such as apple rings, for example. It is also suitable for the preliminary dewatering of cut lettuce and other leafy products.

The product falls from an infeed belt onto the entry belt and is dewatered at two stations. The combination of air knives and suction fans removes the water adhering to the product particularly effectively. A knocking station positioned in front of each blower unit distributes the product evenly across the entire width of the belt to ensure an optimum dewatering result. A noise reduction box reduces the noise level of the suction fans and the air guide inside the box separates water from the airflow in a controlled manner.

Product groups



The machine achieves a product with a residual moisture of approximately 6 to 8 percent without excessive mechanical stress. If the HFDS 2500/600 is used for the preliminary dewatering of lettuce, an additional dewatering step, e.g. with the **BDS 3000/800** belt dewatering system or with a continuous centrifuge such as the K650, is installed as an upstream or downstream unit.



Benefits

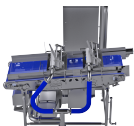

Flexible settings and easy cleaning

The air jet intensity and belt speed can be controlled by means of a frequency converter. The air knives are height-adjustable in several steps and can therefore be adjusted to match the size of the product. The suction power can be varied by means of an adjustable air supply opening. The mesh grid belt is available in different sizes (1000, 2000 and 3000 ?m). The side guides on the belt can be folded down to make cleaning easier. The open construction made of stainless steel and with easy access to the pipework also guarantees an optimal hygienic design.

Technical data

Electrical power	Power	15 kW
	Voltage	3~400 V N/PE
	Frequency	50 Hz
Dimensions	LxWxH	2550 x 1545 x 1900 mm (+/- 50 mm)
	Weight	950 kg
	Infeed/placement height	1040 mm (+/- 50 mm)
	Outfeed/delivery height	1220 mm (+/- 50 mm)
Miscellaneous	Belt width	600 mm
	Height of raw product	max. 150 mm

The data indicated are standard information. In addition, adaptation to other supply networks (e.g. 230V/60 Hz) is optionally possible (except for manual and pneumatic machines). Subject to changes.